

PHOTOZINE



LOOK OUT 2007



END MILLS





FR FRAISES EN BOUT
IT FRESE PER SPALLAMENTO
ES FRESAS DE MANGO

ADAPTION ACC. TO DIN 1835 B (WELDON) / ATTACHEMENT DIN 1835 B (WELDON)
 ATTACCO DIN 1835 B (WELDON) / ADAPTACIÓN SEGÚN DIN 1835 B (WELDON)

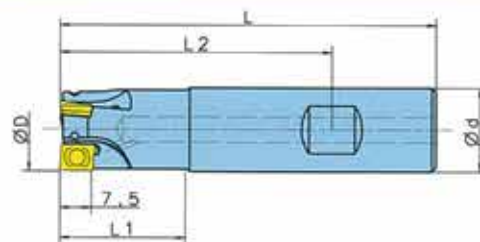

Designation / Réf. de l'article
 Artículo / Referencia

	D	d	L	L1	L2	Z		kg
SA.010.002	9,5	16	80	18	56	1	✓	0,08
SA.010.001	10	16	80	18	56	1	✓	0,08
SA.012.002	11,5	16	80	20	56	1	✓	0,09
SA.012.001	12	16	80	20	56	1	✓	0,09
SA.014.002	13,5	16	80	22	56	1	✓	0,09
SA.014.001	14	16	80	22	56	1	✓	0,09
SA.016.002	15,5	16	85	26	61	2	✓	0,10
SA.016.001	16	16	85	26	61	2	✓	0,10
SA.018.002	17,5	20	85	26	60	2	✓	0,16
SA.018.001	18	20	85	26	60	2	✓	0,16
SA.020.003	19,5	20	90	30	65	3	✓	0,18
SA.020.001	20	20	90	30	65	3	✓	0,18
SA.020.002	20	20	125	75	100	2	✓	0,25
SA.025.006	25	25	100	40	68	3	✓	0,32
SA.025.001	25	25	100	40	68	4	✓	0,32
SA.025.003	25	25	145	85	113	3	✓	0,47
SA.032.001	32	32	100	38	64	5	✓	0,54
SA.032.003	32	32	155	93	119	4	✓	0,85

END MILLS

INSERTS / PLAQUETTES DE COUPE INSERTI / PLAQUITA

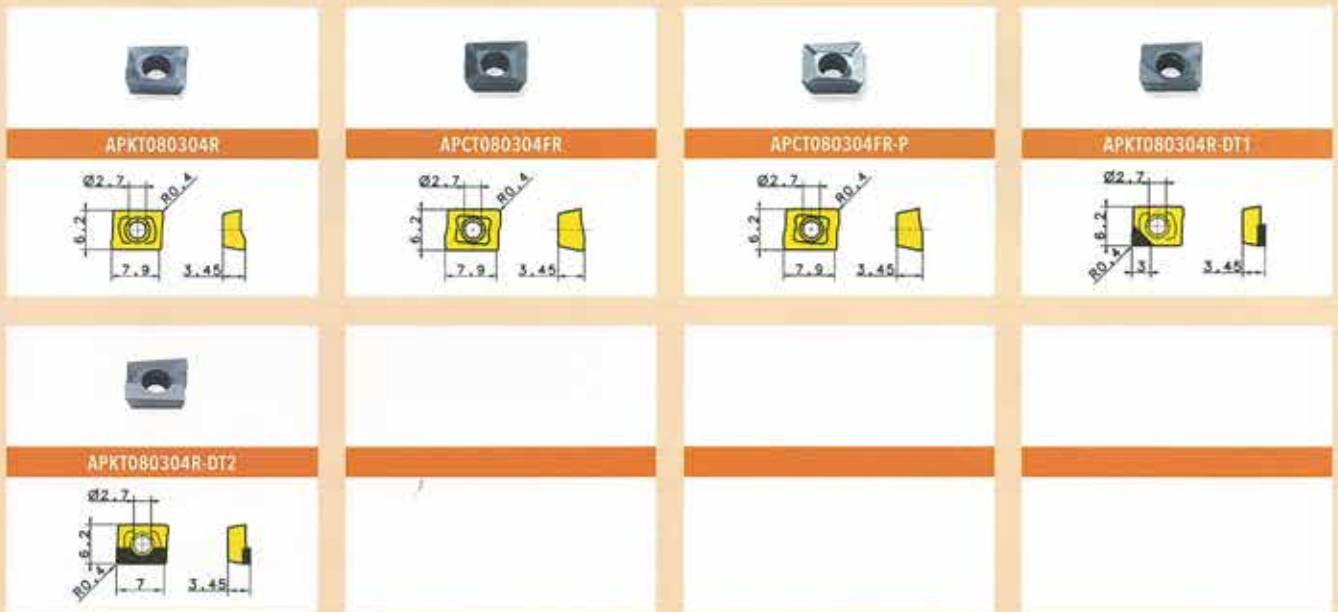

Designation / Réf. de l'article Artículo / Referencia	Insert Version / Execution Tipología Inserto / Tipo de Plaquita	Grades Aliances Grados	IN30M	IN1030	NewGen IN2005	IN2015	IN2030	IN2040	IN60C	IN90D
APKT080304R	positive geometry				●	●	●	●	●	●
APCT080304FR	non-ferrous geometry			●						
APCT080304FR-P	non-ferrous geometry, polished		●							
APKT080304R-DT1	with short PCD-tip									●
APKT080304R-DT2	with long PCD-tip									●

● = P ● = M ● = K ● = N ○ = S ○ = H

SPARE PARTS / ACCESSOIRE RICAMBI / RECAMBIO

Diameter Range / Plage de diamètre Campo diámetro / Rango de diámetros	Insert Screw / Vis de serrage Vite per inserto / Tornillo plaquita	Screw Driver / Tournevis Cacciavite / Destornillador
9,5 - 14 15,5 - 32	SM25-054-00 SM25-064-00 	DS-T08S DS-T08S 



FB FRAISES EN BOUT
IT FRESE PER SPALLAMENTO
ES FRESAS DE MANGO

MODULAR MILLING ADAPTOR / ATTACHEMENT MODULAIRE
 CON ATTACCO MODULARE / FRESA CON CONEXIÓN MODULAR

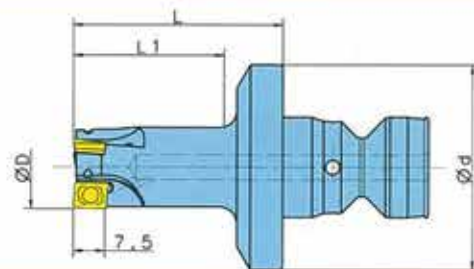

Designation / Réf. de l'article
 Artículo / Referencia

Designation / Réf. de l'article Artículo / Referencia	D	d	L	L1	Z	MOD	IK	kg
SA.010.003	10	49	40	22	1	40	✓	0,25
SA.012.003	12	49	40	22	1	40	✓	0,26
SA.014.003	14	49	40	22	1	40	✓	0,26
SA.016.003	16	49	45	28	2	40	✓	0,27
SA.018.003	18	49	45	28	2	40	✓	0,29
SA.020.004	20	49	50	36	3	40	✓	0,30
SA.020.006	20	49	70	56	3	40	✓	0,34
SA.020.005	20	49	90	76	2	40	✓	0,38
SA.025.002	25	49	55	41	4	40	✓	0,35
SA.025.004	25	49	80	66	3	40	✓	0,44
SA.025.005	25	49	100	86	3	40	✓	0,50
SA.032.002	32	49	55	41	5	40	✓	0,45
SA.032.004	32	49	80	66	4	40	✓	0,59
SA.032.005	32	49	110	96	4	40	✓	0,76

HIPDS SA08M01

END MILLS

INSERTS / PLAQUETTES DE COUPE INSERTI / PLAQUITA



APKT080304R

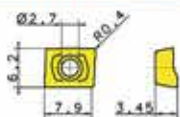

APCT080304FR

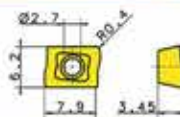

APCT080304FR-P

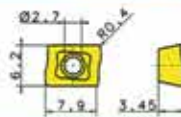

APKT080304R-DT1

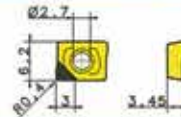

APKT080304R-DT2

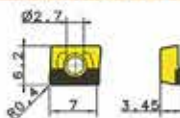

Designation / Réf. de l'article Articolo / Referencia	Insert Version / Execution Tipologia Inserto / Tipo de Plaquita	Grade Nuance Grado Grado	IN30M	IN1030	New Gen IN2005	IN2015	IN2030	IN2040	IN60C	IN90D
APKT080304R	positive geometry				●	●	●	●	●	●
APCT080304FR	non-ferrous geometry				●					
APCT080304FR-P	non-ferrous geometry, polished		●							
APKT080304R-DT1	with short PCD-tip									●
APKT080304R-DT2	with long PCD-tip									●

● = P ● = M ● = K ● = N ○ = S ○ = H

SPARE PARTS / ACCESSOIRE RICAMBI / RECAMBIO

Diameter Range / Plage de diamètre.
Campo diámetro / Rango de diámetros

10 - 14
16 - 32

Insert Screw / Vis de serrage
Vite per inserto / Tornillo plaquita

SM25-054-00
SM25-064-00



Screw Driver / Tournevis
Cacciavite / Destornillador

DS-T08S
DS-T08S





FR FRAISES EN BOUT
 IT FRESE PER SPALLAMENTO
 ES FRESAS DE MANGO



SCREW-TYPE ADAPTION / ATTACHEMENT FILETÉ
 ATTACCO FILETTATO / ADAPTACIÓN MEDIANTE ROSCA

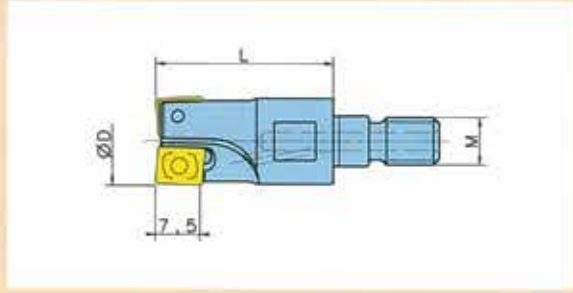

Designation / Réf. de l'article Articolo / Referencia	D	L	M	Z		
SA.012.004	12	30	6	1	✓	0,02
SA.015.001	15	30	8	2	✓	0,03
SA.016.007	16	35	8	2	✓	0,04
SA.020.013	20	35	10	3	✓	0,06
SA.025.013	25	35	12	4	✓	0,10
SA.032.017	32	43	16	5	✓	0,22

HIPOS SA08E01

END MILLS

INSERTS / PLAQUETTES DE COUPE INSERTI / PLAQUITA



APKT080304R

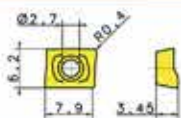

APCT080304FR

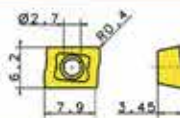

APCT080304FR-P

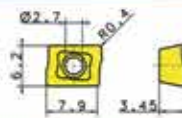

APKT080304R-DT1

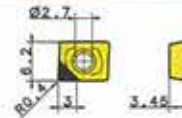

APKT080304R-DT2

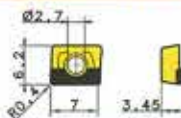

Designation / Réf. de l'article Articolo / Referencia	Insert Version / Execution Tipologia Inserto / Tipo de Plaquita	Grade Inquente Grado	IN30M	IN1030	NewGen IN2005	IN2015	IN2030	IN2040	IN60C	IN90D
--	--	----------------------------	-------	--------	-------------------------	--------	--------	--------	-------	-------

APKT080304R	positive geometry				●	●	●	●	●	●
APCT080304FR	non-ferrous geometry			●						
APCT080304FR-P	non-ferrous geometry, polished		●							
APKT080304R-DT1	with short PCD-tip									●
APKT080304R-DT2	with long PCD-tip									●

● = P ● = M ● = K ● = N ○ = S ○ = H

SPARE PARTS / ACCESSOIRE RICAMBI / RECAMBIO

Diameter Range / Plage de diamètre
Campo diámetro / Rango de diámetros

12 - 15
16 - 32

Insert Screw / Vis de serrage
Vite per inserto / Tornillo plaquita

SM25-054-00
SM25-064-00



Screw Driver / Tournevis
Cacciavite / Destornillador

DS-T08S
DS-T08S





FB FRAISES EN BOUT
IT FRESE PER SPALLAMENTO
ES FRESAS DE MANGO



ADAPTION ACC. TO DIN 1835 B (WELDON) / ATTACHEMENT DIN 1835 B (WELDON)
 ATTACCO DIN 1835 B (WELDON) / ADAPTACIÓN SEGÚN DIN 1835 B (WELDON)

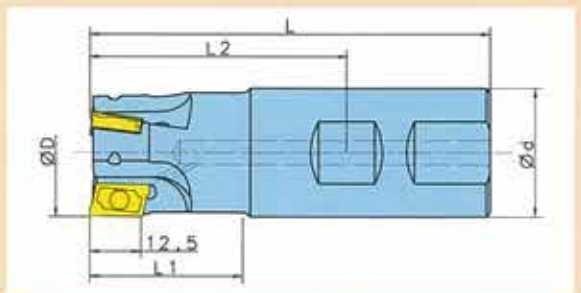

Designation / Réf. de l'article
 Articolo / Referencia

D d L L1 L2 Z

Ⓚ kg

SB.025.001	25	25	100	40	68	2	✓	0,31
SB.025.002	25	25	145	85	113	2	✓	0,45
SB.032.001	32	32	100	38	64	3	✓	0,51
SB.032.002	32	32	185	120	149	2	✓	0,98

END MILLS

INSERTS / PLAQUETTES DE COUPE INSERTI / PLAQUITA

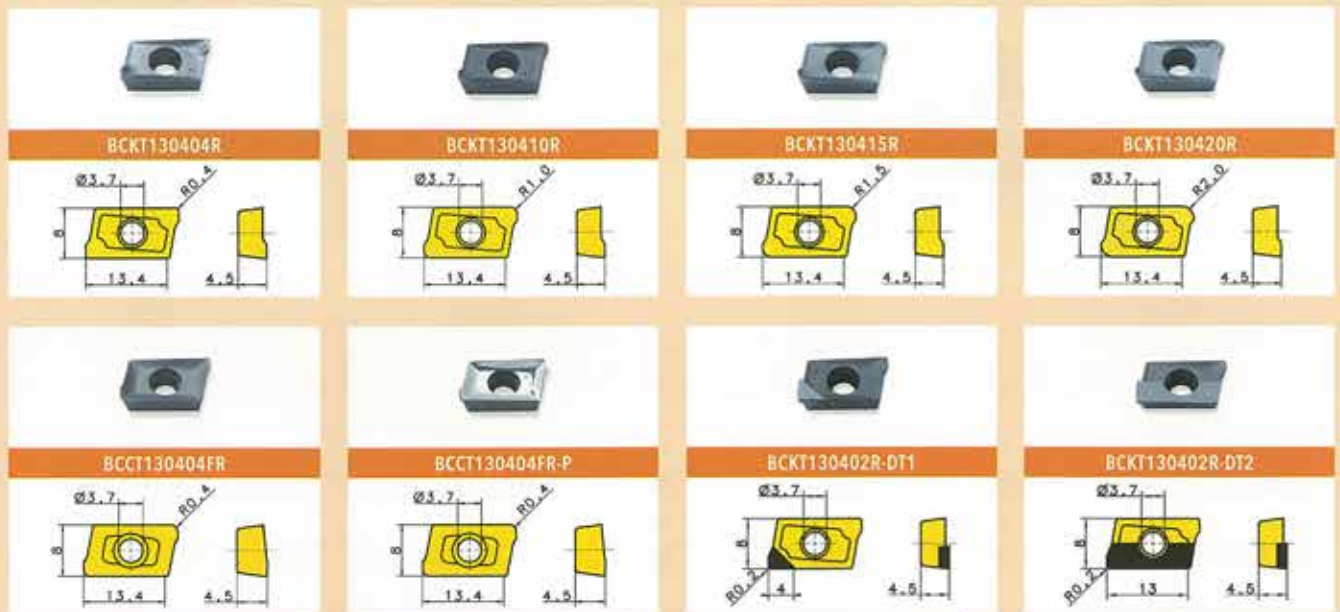

Designation / Réf. de l'article Articolo / Referencia	Insert Version / Execution Tipologia Inserto / Tipo de Plaquita	Grade Insercio Grado	IN30M	IN1030	New Gen IN2005	IN2015	IN2030	IN2040	IN60C	IN90D
BCKT130404R	positive geometry R0,4				●	●	●	●	●	●
BCKT130410R	positive geometry R1,0				●			●		
BCKT130415R	positive geometry R1,5				●			●		
BCKT130420R	positive geometry R2,0				●			●		
BCCT130404FR	non-ferrous geometry R0,4				●					
BCCT130404FR-P	non-ferrous geometry, polished R0,4		●							
BCKT130402R-DT1	with short PCD-tip									●
BCKT130402R-DT2	with long PCD-tip									●

● = P ● = M ● = K ● = N ○ = S ○ = H

SPARE PARTS / ACCESSOIRE RICAMBI / RECAMBIO

Insert Screw / Vis de serrage Vite per inserto / Tornillo plaquita	Screw Driver / Tournevis Cacciavite / Destornillador
SM35-088-10 	DS-T105 



FR FRAISES EN BOUT
 IT FRESE PER SPALLAMENTO
 ES FRESAS DE MANGO

MODULAR MILLING ADAPTOR / ATTACHEMENT MODULAIRE
 CON ATTACCO MODULARE / FRESA CON CONEXIÓN MODULAR

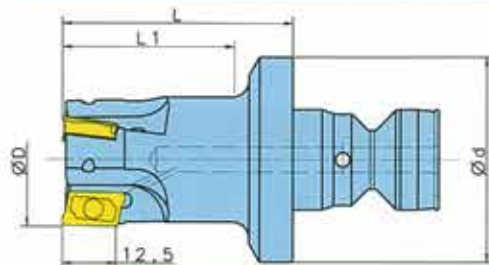

Designation / Réf. de l'article
 Artículo / Referencia

Ø d L L1 Z MOD



SB.025.003	25	49	55	41	2	40	✓	0,34
SB.025.004	25	49	100	87	2	40	✓	0,49
SB.032.003	32	49	55	41	3	40	✓	0,41
SB.032.004	32	49	135	122	2	40	✓	0,85

END MILLS

INSERTS / PLAQUETTES DE COUPE INSERTI / PLAQUITA



BCKT130404R

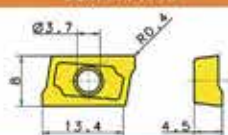

BCKT130410R

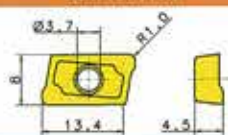

BCKT130415R

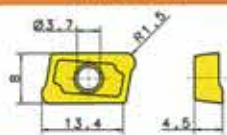

BCKT130420R

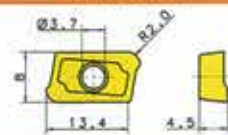

BCCT130404FR

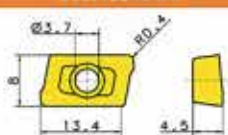

BCCT130404FR-P

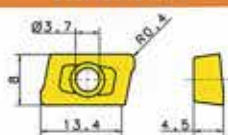

BCKT130402R-DT1



BCKT130402R-DT2

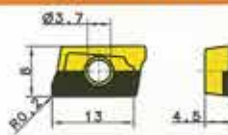

Designation / Réf. de l'article
Articolo / Referencia

Insert Version / Execution
Tipologia Inserto / Tipo de Plaquita

Grade
Nunçie
Grado
Grado

IN30M

IN1030

New Gen
IN2005

IN2015

IN2030

IN2040

IN60C

IN90D

BCKT130404R

positive geometry R0,4

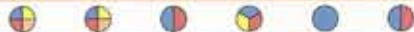

BCKT130410R

positive geometry R1,0



BCKT130415R

positive geometry R1,5



BCKT130420R

positive geometry R2,0

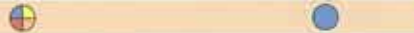

BCCT130404FR

non-ferrous geometry R0,4



BCCT130404FR-P

non-ferrous geometry, polished R0,4



BCKT130402R-DT1

with short PCD-tip



BCKT130402R-DT2

with long PCD-tip



● = P ● = M ● = K ● = N ○ = S ○ = H

SPARE PARTS / ACCESSOIRE RICAMBI / RECAMBIOS

Insert Screw / Vis de serrage
Vite per inserto / Tornillo plaquita

SM35-088-10



Screw Driver / Tournevis
Cacciavite / Destornillador

DS-T10S



HELICAL END MILLS





FR FRAISES HÉRISSEON
IT FRESE ELICOIDALI
ES FRESA CILÍNDRICA FRONTAL

ADAPTION ACC. TO DIN 1835 B (WELDON) / ATTACHEMENT DIN 1835 B (WELDON)
 ATTACCO DIN 1835 B (WELDON) / ADAPTACIÓN SEGÚN DIN 1835 B (WELDON)

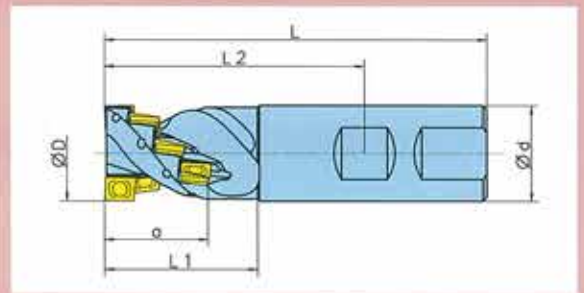

Designation / Réf. de l'article / Artículo / Referencia D d L L1 L2 a Z Zeff kg

IA.020.001	20	20	90	30	65	20	6	2	0,18
IA.025.001	25	25	100	40	68	26	8	2	0,30

INSERTS / PLAQUETTES DE COUPE
INSERTI / PLAQUITA

APKT080304R	APCT080304FR	APCT080304FR-P	

Designation / Réf. de l'article / Artículo / Referencia	Insert Version / Execution / Tipología Inserto / Tipo de Plaquita	Grade / Matière / Grado	IN30M	IN1030	IN2005	IN2015	IN2030	IN2040	IN60C
APKT080304R	positive geometry								
APCT080304FR	non-ferrous geometry								
APCT080304FR-P	non-ferrous geometry, polished								

= P = M = K = N = S = H

SPARE PARTS / ACCESSOIRE
RICAMBI / RECAMBIOS

Insert Screw / Vis de serrage / Vite per inserto / Tornillo plaquita	Screw Driver / Tournevis / Cacclavite / Destornillador		
SM25-064-00	DS-T08S		

HIPDS IA08D03

HELICAL END MILLS

MODULAR MILLING ADAPTOR / ATTACHEMENT MODULAIRE
CON ATTACCO MODULARE / FRESA CON CONEXIÓN MODULAR

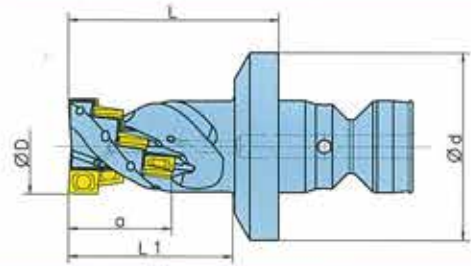

Designation / Réf. de l'article
Artículo / Referencia

D d L L1 a Z Zeff MOD



IA.020.002	20	49	45	30	20	6	2	40	✓	0,28
IA.025.002	25	49	55	43	26	8	2	40	✓	0,32

INSERTS / PLAQUETTES DE COUPE
INSERTI / PLAQUITA



APKT080304R

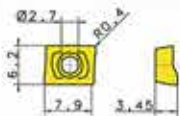

APCT080304FR

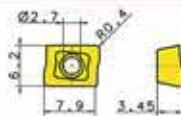

APCT080304FR-P

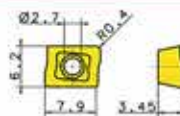

Designation / Réf. de l'article
Artículo / Referencia

Insert Version / Execution
Tipología Inserto / Tipo de Plaquita

Grade
Nuance
Grado
Grado

IN30M

IN1030

IN2005 *New Gen*

IN2015

IN2030

IN2040

IN60C

APKT080304R

positive geometry



APCT080304FR

non-ferrous geometry



APCT080304FR-P

non-ferrous geometry, polished



● = P ● = M ● = K ● = N ● = S ● = H

SPARE PARTS / ACCESSOIRE
RICAMBI / RECAMBIOS

Insert Screw / Vis de serrage
Vite per inserto / Tornillo plaquita

SM25-064-00



Screw Driver / Tournevis
Cacclavite / Destornillador

DS-T08S



HIPOS IA08M01

HIPOS



FR FRAISES HÉRISSEON
 IT FRESE ELICOIDALI
 ES FRESA CILÍNDRICA FRONTAL



ADAPTION ACC. TO DIN 1835 B (WELDON) / ATTACHEMENT DIN 1835 B (WELDON)
 ATTACCO DIN 1835 B (WELDON) / ADAPTACIÓN SEGÚN DIN 1835 B (WELDON)

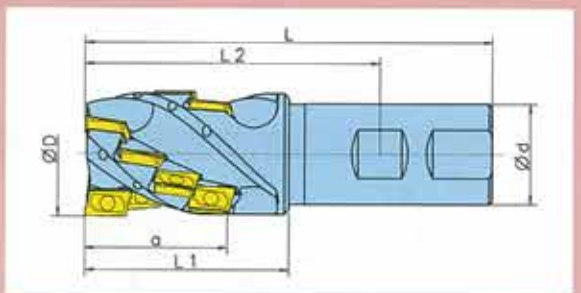

Designation / Réf. de l'article
 Articolo / Referencia

	D	d	L	L1	L2	a	Z	Z _{eff}	kg
IB.032.001	32	32	110	45	74	35	6	2	0,55
IB.040.001	40	32	130	65	94	46	12	3	0,78

HIPBS IB13D03

HELICAL END MILLS

INSERTS / PLAQUETTES DE COUPE INSERTI / PLAQUITA

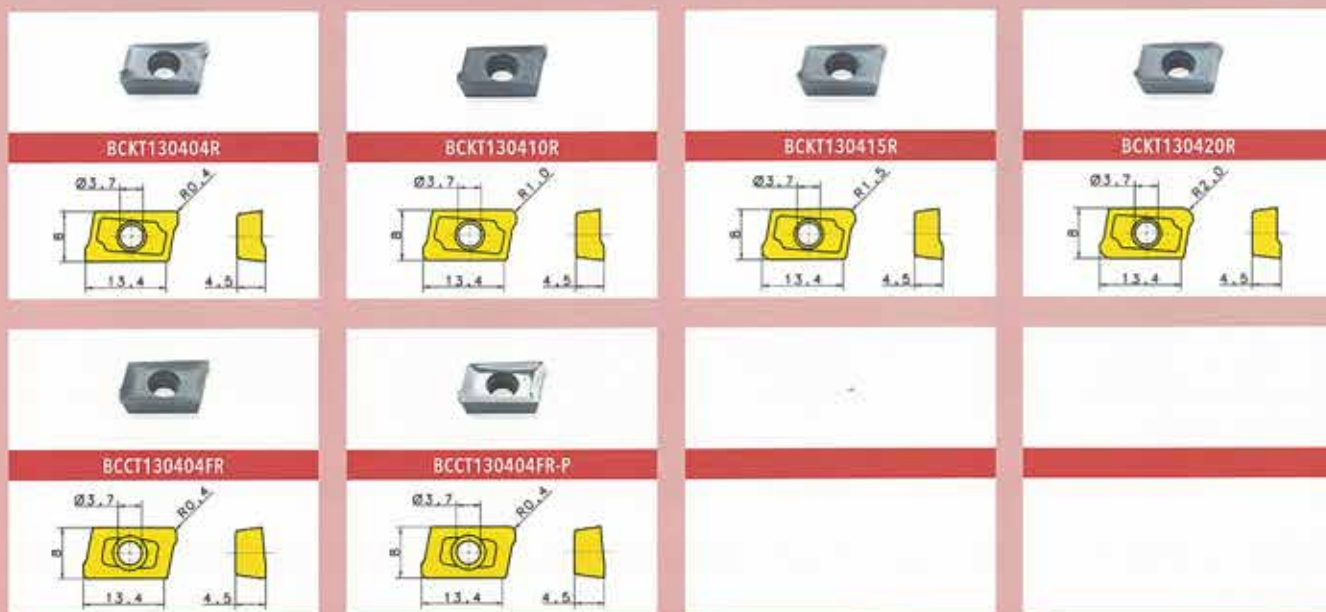

Designation / Réf. de l'article Articolo / Referencia	Insert Version / Execution Tipologia Inserto / Tipo de Plaquita	Grade / Nuance / Grado / Grado						
		IN30M	IN1030	IN2005	IN2015	IN2030	IN2040	IN60C
BCKT130404R	positive geometry R0,4							
BCKT130410R	positive geometry R1,0							
BCKT130415R	positive geometry R1,5							
BCKT130420R	positive geometry R2,0							
BCCT130404FR	non-ferrous geometry R0,4							
BCCT130404FR-P	non-ferrous geometry, polished R0,4							

● = P ● = M ● = K ● = N ● = S ● = H

SPARE PARTS / ACCESSOIRE RICAMBI / RECAMBIOS

Insert Screw / Vis de serrage Vite per inserto / Tornillo plaquita

SM35-088-10



Screw Driver / Tournevis Cacciavite / Destornillador

DS-T105





FR FRAISES HÉRISSON
 IT FRESE ELICOIDALI
 ES FRESA CILÍNDRICA FRONTAL



ADAPTION ACC. TO DIN 8030 / ATTACHEMENT DIN 8030
 ATTACCO DIN 8030 / ADAPTACIÓN SEGÚN DIN 8030

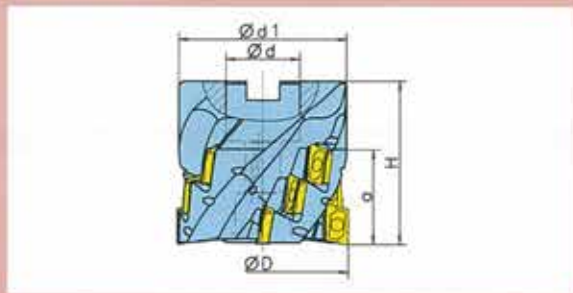

Designation / Réf. de l'article
 Artículo / Referencia

D d H a d1 Z Zeff



IB.050.001	50	27	50	24	47,5	6	3	✓	0,41
IB.063.001	63	27	60	35	61,6	12	4	✓	0,85
IB.080.001	80	32	65	35	77	15	5	✓	1,60

HIPOB IB13D10

HELICAL END MILLS

INSERTS / PLAQUETTES DE COUPE INSERTI / PLAQUITA



BCKT130404R

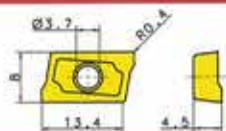

BCKT130410R

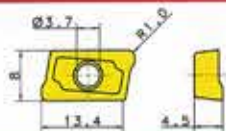

BCKT130415R

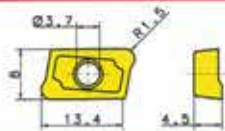

BCKT130420R

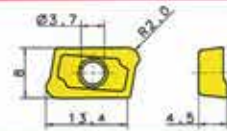

BCCT130404FR

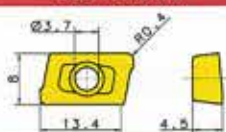

BCCT130404FR-P

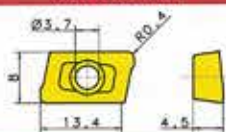

Designation / Réf. de l'article Artículo / Referencia	Insert Version / Execution Tipología Inserto / Tipo de Plaquita	Grade Nuance Grado Grado	IN30M	IN1030	IN2005	IN2015	IN2030	IN2040	IN60C
BCKT130404R	positive geometry R0,4		●	●	●	●	●	●	●
BCKT130410R	positive geometry R1,0		●					●	●
BCKT130415R	positive geometry R1,5		●					●	
BCKT130420R	positive geometry R2,0		●					●	
BCCT130404FR	non-ferrous geometry R0,4		●						
BCCT130404FR-P	non-ferrous geometry, polished R0,4		●						

● = P ● = M ● = K ● = N ● = S ○ = H

SPARE PARTS / ACCESSOIRE RICAMBI / RECAMBIOS

Insert Screw / Vis de serrage
Vite per inserto / Tornillo plaquita

SM35-088-10



Screw Driver / Tournevis
Cacciavite / Destornillador

DS-T10S





FB FRAISES HÉRISSEON
 IT FRESE ELICOIDALI
 ES FRESA CILÍNDRICA FRONTAL

MODULAR MILLING ADAPTOR / ATTACHEMENT MODULAIRE
 CON ATTACCO MODULARE / FRESA CON CONEXIÓN MODULAR

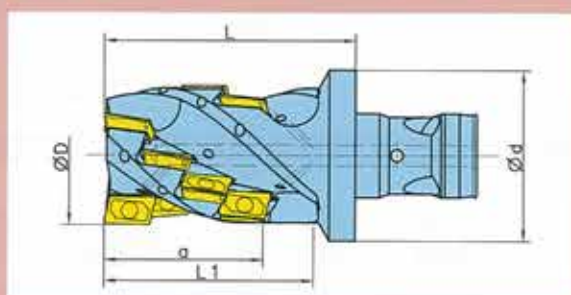

Designation / Réf. de l'article
 Artículo / Referencia

Designation / Réf. de l'article Artículo / Referencia	D	d	L	L1	a	Z	Zeff	MOD	IK	kg
IB.032.002 ¹⁾	32	49	55	43	35	6	2	40	✓	0,36
IB.040.002 ¹⁾	40	49	65	55	46	8	2	40	✓	0,49
IB.040.004	40	49	72	60	46	12	3	40	✓	0,56
IB.040.003 ¹⁾	40	78	72	55	46	8	2	50	✓	1,06
IB.040.005	40	78	72	55	46	12	3	50	✓	1,12
IB.040.006	40	49	94	82	68	18	3	40	✓	0,66
IB.040.007	40	78	94	77	68	18	3	50	✓	1,22
IB.050.002 ¹⁾	50	49	65	65	46	8	2	40	✓	0,69
IB.050.006	50	49	65	65	46	12	3	40	✓	0,72
IB.050.003 ¹⁾	50	78	72	55	46	8	2	50	✓	1,29
IB.050.004	50	78	72	55	46	12	3	50	✓	1,34
IB.050.007	50	49	94	82	68	18	3	40	✓	1,45
IB.050.005	50	78	94	77	68	18	3	50	✓	1,52
IB.063.002	63	78	94	80	68	18	3	50	✓	2,02
IB.063.003	63	78	116	102	90	24	3	50	✓	2,36
IB.063.004	63	78	138	124	112	30	3	50	✓	2,67
IB.063.005	63	78	160	146	134	36	3	50	✓	3,00
IB.080.002	80	78	116	116	90	32	4	50	✓	3,50

HIPOS IB13M01

¹⁾ Recommended for Slotting / Recommandé pour le rainurage dans le plein / Consigliata per fresatura dal pieno / Preferentemente para ranurado completo

HELICAL END MILLS

INSERTS / PLAQUETTES DE COUPE INSERTI / PLAQUITA

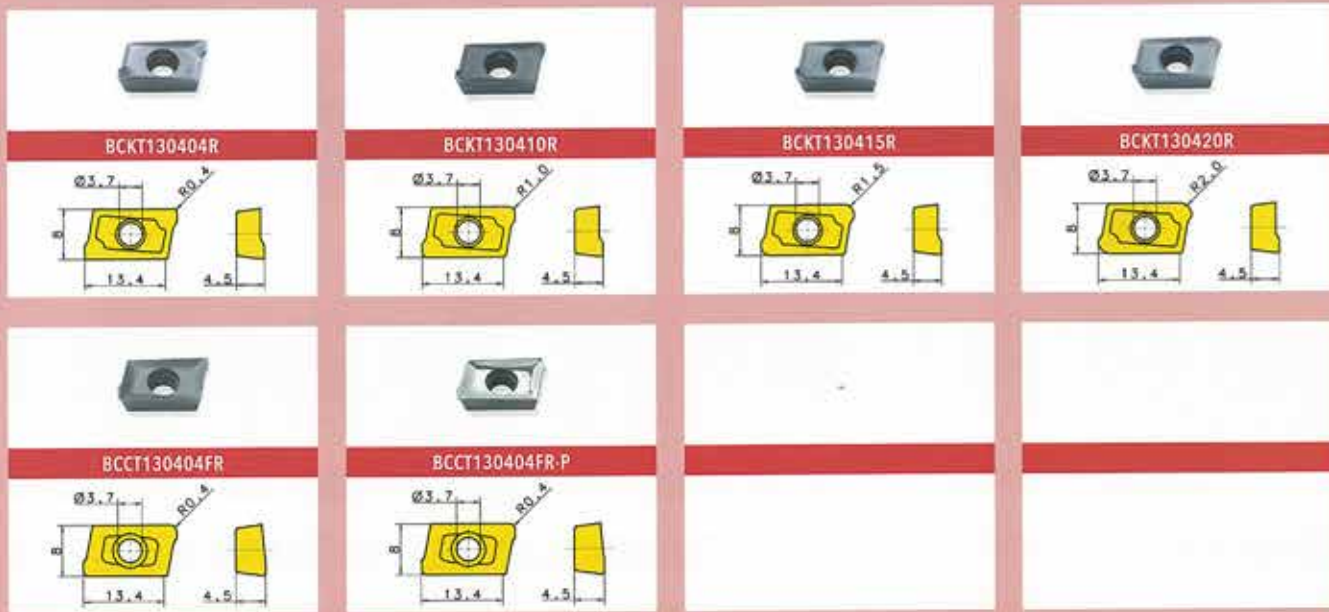

Designation / Réf. de l'article Articolo / Referencia	Insert Version / Execution Tipologia Inserto / Tipo de Plaquita	Grade Nuance Código Grado	IN30M	IN1030	IN2005	IN2015	IN2030	IN2040	IN60C	NEW GEN	
BCKT130404R	positive geometry R0,4										
BCKT130410R	positive geometry R1,0										
BCKT130415R	positive geometry R1,5										
BCKT130420R	positive geometry R2,0										
BCCT130404FR	non-ferrous geometry R0,4										
BCCT130404FR-P	non-ferrous geometry, polished R0,4										

● = P ● = M ● = K ● = N ● = S ● = H

SPARE PARTS / ACCESSOIRE RICAMBI / RECAMBIOS

Insert Screw / Vis de serrage
Vite per inserto / Tornillo plaquita

SM35-088-10



Screw Driver / Tournevis
Cacciavite / Destornillador

DS-T10S



SQUARE SHOULDER CUTTERS





FR FRAISES À SURFACER DRESSER
IT FRESE 90° A MANICOTTO
ES FRESA ANGULAR

ADAPTION ACC. TO DIN 8030 / ATTACHEMENT DIN 8030
 ATTACCO DIN 8030 / ADAPTACIÓN SEGÚN DIN 8030

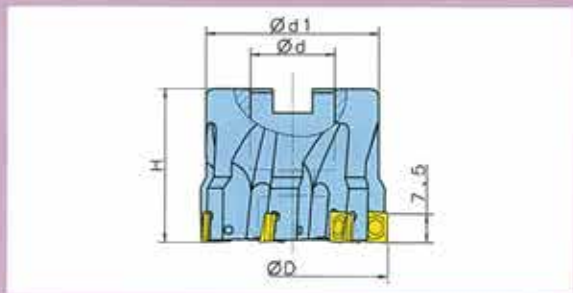

Designation / Réf. de l'article
 Articolo / Referencia

D d H d1 Z



EA.032.001	32	16	32	30	5	0,10
EA.040.001	40	22	40	38	6	0,22
EA.050.001	50	22	40	45	7	0,34
EA.063.001	63	22	40	55	8	0,59
EA.080.001	80	27	50	70	10	1,23
EA.100.001	100	32	50	85	12	2,03

SQUARE SHOULDER CUTTERS

INSERTS / PLAQUETTES DE COUPE
INSERTI / PLAQUITA



APKT080304R

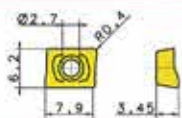

APCT080304FR

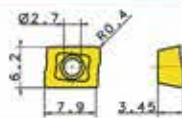

APCT080304FR-P

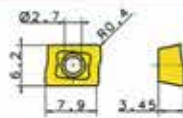

APKT080304R-DT1

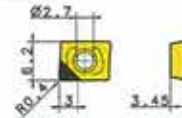

APKT080304R-DT2

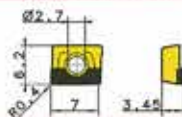

Designation / Réf. de l'article Articolo / Referencia	Insert Version / Execution Tipologia Inserto / Tipo de Plaquita	Grade Nuance Código Grado	IN30M	IN1030	IN2005	IN2015	IN2030	IN2040	IN60C	IN90D
APKT080304R	positive geometry			●	●	●	●	●	●	●
APCT080304FR	non-ferrous geometry			●						
APCT080304FR-P	non-ferrous geometry, polished		●							
APKT080304R-DT1	with short PCD-tip									●
APKT080304R-DT2	with long PCD-tip									●

● = P ● = M ● = K ● = N ● = S ○ = H

SPARE PARTS / ACCESSOIRE
RICAMBI / RECAMBIO

Insert Screw / Vis de serrage
Vite per inserto / Tornillo plaquita

SM25-064-00



Screw Driver / Tournevis
Cacciavite / Destornillador

DS-T08S





FR FRAISES À SURFACER DRESSER
IT FRESE 90° A MANICOTTO
ES FRESA ANGULAR



ADAPTION ACC. TO DIN 8030 / ATTACHEMENT DIN 8030
 ATTACCO DIN 8030 / ADAPTACIÓN SEGÚN DIN 8030

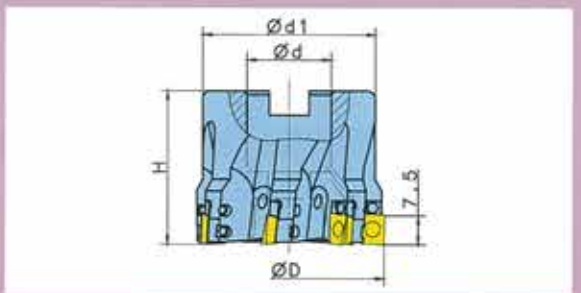

Designation / Réf. de l'article
 Artículo / Referencia

D	d	H	d1	Z	IK	kg	
EA.032.002	32	16	32	30	5	✓	0,10
EA.040.002	40	22	40	38	6	✓	0,21
EA.050.002	50	22	40	45	7	✓	0,34
EA.063.002	63	22	40	55	8	✓	0,59
EA.080.002	80	27	50	70	10	✓	1,23
EA.100.002	100	32	50	85	12	✓	2,02

HIPDS EA08D10A (ADJUSTABLE)

SQUARE SHOULDER CUTTERS

INSERTS / PLAQUETTES DE COUPE
INSERTI / PLAQUITA

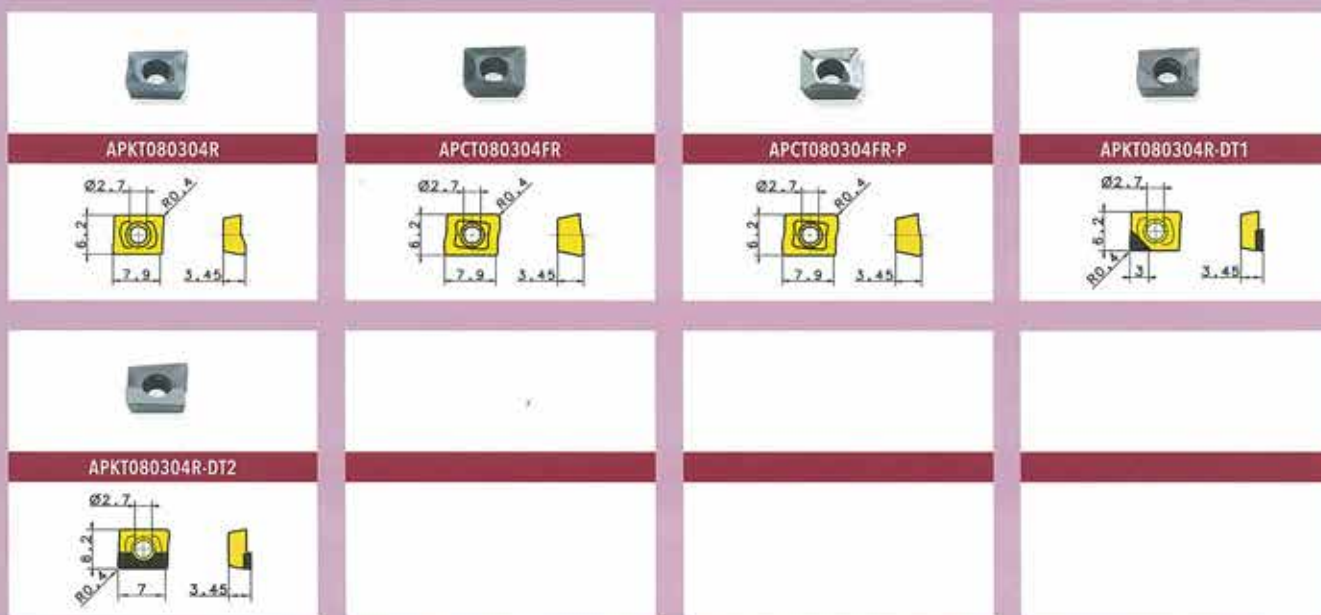

Designation / Réf. de l'article Artículo / Referencia	Insert Version / Execution Tipología Inserto / Tipo de Plaquita	Grade Nuance Grado Grado	IN30M	IN1030	IN2005	IN2015	IN2030	IN2040	IN60C	IN90D
APKT080304R	positive geometry			●	●	●	●	●	●	●
APCT080304FR	non-ferrous geometry			●						
APCT080304FR-P	non-ferrous geometry, polished		●							
APKT080304R-DT1	with short PCD-tip									●
APKT080304R-DT2	with long PCD-tip									●

● = P ● = M ● = K ● = N ● = S ● = H

SPARE PARTS / ACCESSOIRE
RICAMBI / RECAMBIOS

Insert Screw / Vis de serrage Vite per inserto / Tornillo plaquita	Screw Driver / Tournevis Cacciavite / Destornillador	Wedge / cône de réglage Spigolo / Cuña presión	Differential Screw / Vis à pas différentiel Cacciavite dynamométrico / Tornillo diferencial
SM25-064-00 	DS-T08S 	PAR5061 	SB025-00 
DS-T05F 			



FB FRAISES À SURFACER DRESSER
IT FRESE 90° A MANICOTTO
ES FRESA ANGULAR



ADAPTION ACC. TO DIN 8030 / ATTACHEMENT DIN 8030
 ATTACCO DIN 8030 / ADAPTACIÓN SEGÚN DIN 8030

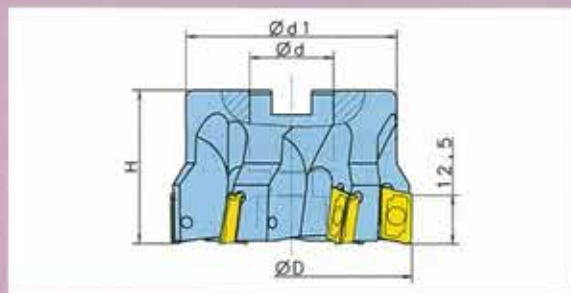

Designation / Réf. de l'article Articolo / Referencia	D	d	H	d1	Z	IK	kg
EB.040.001	40	22	40	38	4	✓	0,20
EB.050.001	50	22	40	45	5	✓	0,32
EB.063.001	63	22	40	55	6	✓	0,54
EB.080.001	80	27	50	70	6	✓	1,20
EB.100.001	100	32	50	85	8		1,92
EB.125.001	125	40	63	100	9		3,69

SQUARE SHOULDER CUTTERS

INSERTS / PLAQUETTES DE COUPE
INSERTI / PLAQUITA

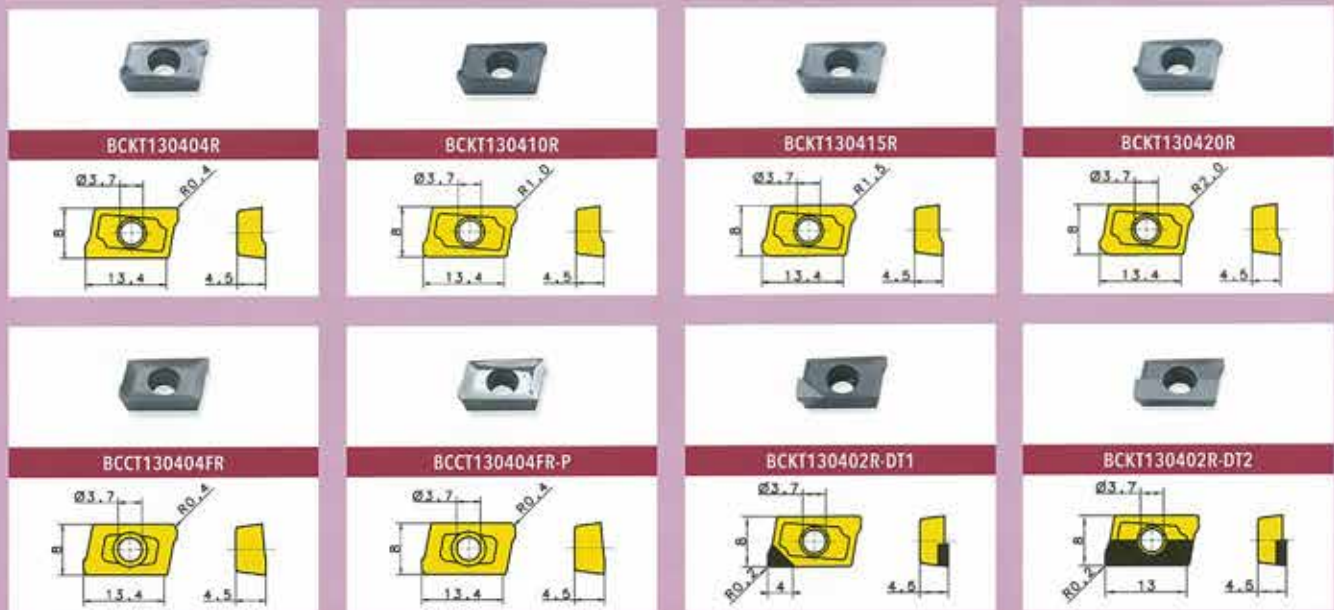

Designation / Réf. de l'article Articolo / Referencia	Insert Version / Execution Tipologia Inserto / Tipo de Plaquita	Grade Aunque Grado Grado	IN30M	IN1030	IN2005	IN2015	IN2030	IN2040	IN60C	IN90D
BCKT130404R	positive geometry R0,4									
BCKT130410R	positive geometry R1,0									
BCKT130415R	positive geometry R1,5									
BCKT130420R	positive geometry R2,0									
BCCT130404FR	non-ferrous geometry R0,4									
BCCT130404FR-P	non-ferrous geometry, polished R0,4									
BCKT130402R-DT1	with short PCD-tip									
BCKT130402R-DT2	with long PCD-tip									

● = P ● = M ● = K ● = N ● = S ● = H

SPARE PARTS / ACCESSOIRE
RICAMBI / RECAMBIO

Insert Screw / Vis de serrage
Vite per inserto / Tornillo plaquita

SM35-088-10

Screw Driver / Tournevis
Cacciavite / Destornillador

DS-T10S

Blank space for spare parts information.

Blank space for spare parts information.

FORM CUTTERS





FB FRAISES DE FORME
 IT FRESE PER SMUSSI E CAVE A T
 ES FRESA PERFILADA



ADAPTION ACC. TO DIN 1835 B (WELDON) / ATTACHEMENT DIN 1835 B (WELDON)
 ATTACCO DIN 1835 B (WELDON) / ADAPTACIÓN SEGÚN DIN 1835 B (WELDON)

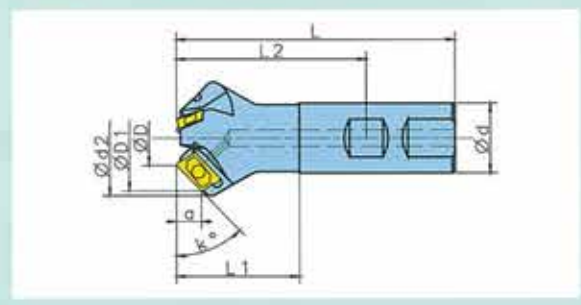

Designation / Réf. de l'article Articolo / Referencia	D	D1	d	L	L1	L2	a	d2	k°	Z		
FB.020.001	20	44,5	25	100	44	68	3,2	-	15	3	✓	0,37
FB.020.002	20	42	25	100	44	68	6,2	-	30	3	✓	0,35
FB.020.003	20	38	25	100	44	68	8,8	41,3	45	3	✓	0,37
FB.020.004	20	32,8	25	100	44	68	10,9	-	60	3	✓	0,34
FB.020.005	20	26,7	25	100	44	68	12,3	-	75	3	✓	0,31

HIPOS FB13D03

FORM CUTTERS

INSERTS / PLAQUETTES DE COUPE
INSERTI / PLAQUITA



BCKT130404R

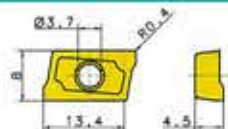

BCKT130410R

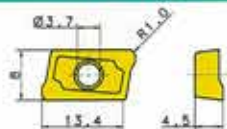

BCKT130415R

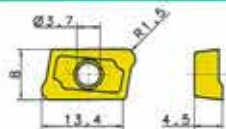

BCKT130420R

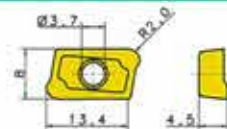

BCCT130404FR

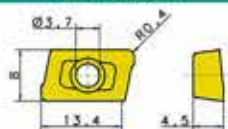

BCCT130404FR-P

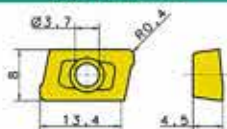

Designation / Réf. de l'article Articolo / Referencia	Insert Version / Execution Tipologia Inserto / Tipo de Plaquita	Grade Qualite Grado Grado	IN30M	IN1030	New Gen IN2005	IN2015	IN2030	IN2040	IN60C
BCKT130404R	positive geometry R0,4			●	●	●	●	●	●
BCKT130410R	positive geometry R1,0			●				●	●
BCKT130415R	positive geometry R1,5			●				●	
BCKT130420R	positive geometry R2,0			●				●	
BCCT130404FR	non-ferrous geometry R0,4			●					
BCCT130404FR-P	non-ferrous geometry, polished R0,4		●						

● = P ● = M ● = K ● = N ● = S ○ = H

SPARE PARTS / ACCESSOIRE
RICAMBI / RECAMBIO

Insert Screw / Vis de serrage
Vite per inserto / Tornillo plaquita

SM35-088-10



Screw Driver / Tournevis
Cacciavite / Destornillador

DS-T10S





FR FRAISES DE FORME
 IT FRESE PER SMUSSI E CAVE A T
 ES FRESA PERFILADA



ADAPTION ACC. TO DIN 8030 / ATTACHEMENT DIN 8030
 ATTACCO DIN 8030 / ADAPTACIÓN SEGÚN DIN 8030

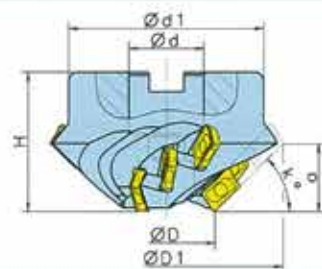

Designation / Réf. de l'article
 Artículo / Referencia

D D1 d H a d1 k° Z Zeff



FB.035.004	35	101,9	27	50	8,8	70	15	9	3	1,47
FB.035.003	35	95,1	27	50	17,2	70	30	9	3	1,24
FB.035.001	35	84,1	27	50	24,5	70	45	9	3	0,99
FB.035.002	35	69,7	27	50	30	70	60	9	3	0,73
FB.035.005	35	53	22	50	33,5	45	75	9	3	0,33

FORM CUTTERS

INSERTS / PLAQUETTES DE COUPE
INSERTI / PLAQUITA



BCKT130404R

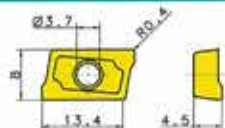

BCKT130410R

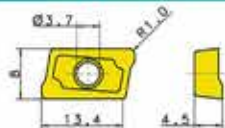

BCKT130415R

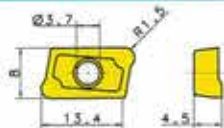

BCKT130420R

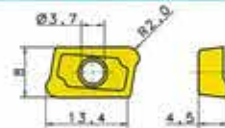

BCCT130404FR

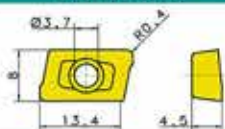

BCCT130404FR-P

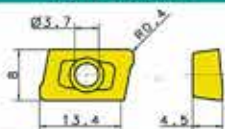

Designation / Réf. de l'article
Articolo / Referencia

Insert Version / Execution
Tipologia Inserto / Tipo de Plaquita

Grade
Nuance
Grado
Grado

IN30M

IN1030

IN2005

IN2015

IN2030

IN2040

IN60C

BCKT130404R

positive geometry R0,4



BCKT130410R

positive geometry R1,0



BCKT130415R

positive geometry R1,5



BCKT130420R

positive geometry R2,0

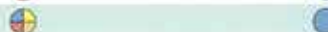

BCCT130404FR

non-ferrous geometry R0,4



BCCT130404FR-P

non-ferrous geometry, polished R0,4



● = P ● = M ● = K ● = N ● = S ○ = H

SPARE PARTS / ACCESSOIRE
RICAMBI / RECAMBIOS

Insert Screw / Vis de serrage
Vite per inserto / Tornillo plaquita

SM35-088-10



Screw Driver / Tournevis
Cacciavite / Destornillador

DS-T10S

